

02

ORG. DE BASE BOITE DE VITESSES
GEARBOX BASIC COMPONENT
GRUNDORGAN GETRIEBE

53

ORGANE BOITE DE VITESSES
GEARBOX COMPONENT
ORGAN GETRIEBE

702

BOITE DE VITESSES OM 2860
GEARBOX OM 2860
GETRIEBE OM 2860

VALIDITE DU
TYPE D'ORGANE

COMPONENT
APPLICABILITY

GÜLTIGKEIT
DES
ORGANTYPES

BOITE DE VITESSES N° :
GEARBOX Nr : 1048
GETRIEBE Nr :

02**53****702**n° édition
cataloguen° de
planche

1

2

3

4

5

Carter et couvercles de boîte de vitesses
Gearbox casing and covers
Getriebe Gehäuse und Deckel

00

01

Carter d'embrayage et commande de surmultiplicateur
Clutch housing and overdrive control
Kupplungsgehäuse und Schnellganggetriebeschaltung

00

02

Pignons de boîte de vitesses
Gearbox gears
Zahnräder und wellen des Getriebes

00

03

Pignons de boîte de vitesses
Gearbox gears
Zahnräder und wellen des Getriebes

00

04

Pignons de boîte de vitesses
Gearbox gears
Zahnräder und wellen des Getriebes

00

05

Commandes intérieures de boîte de vitesses
Gearbox inner controls
Innere Getriebeschaltung

00

06

Prise de mouvement
Drive pick-up
Nebenantrieb

00

07

1	ORGANE DE BASE	BASIC COMPONENT	GRUND-ORGAN
2	ORGANE	COMPONENT	ORGAN
3	TYPE D'ORGANE	COMPONENT TYPE	ORGANTYP
4	N° ÉDITION	CATAL. EDITION NUMBER	NUMMER DER AUSGABE
5	N° PLANCHE	PLATE NUMBER	BILD Nr.
6	REPÈRE	MARKING	KENNZIFFER

7	N° PIÈCE	PART N°	TEIL Nr.
8	DÉSIGNATION	DESIGNATION	BESCHRIFTUNG
9	QUANTITÉ	QUANTITY	MENGE
10	CODE OBSERVATIONS	CODE OF OBSERV.	ANMERKUNGEN KODE
11	DÉTAILS OBSERVATIONS	DETAILS OF OBSERV.	ANMERKUNGEN BEDEUT.

Reference Kennzahl 655.922
 EDITION AUSGABE 15/10/73

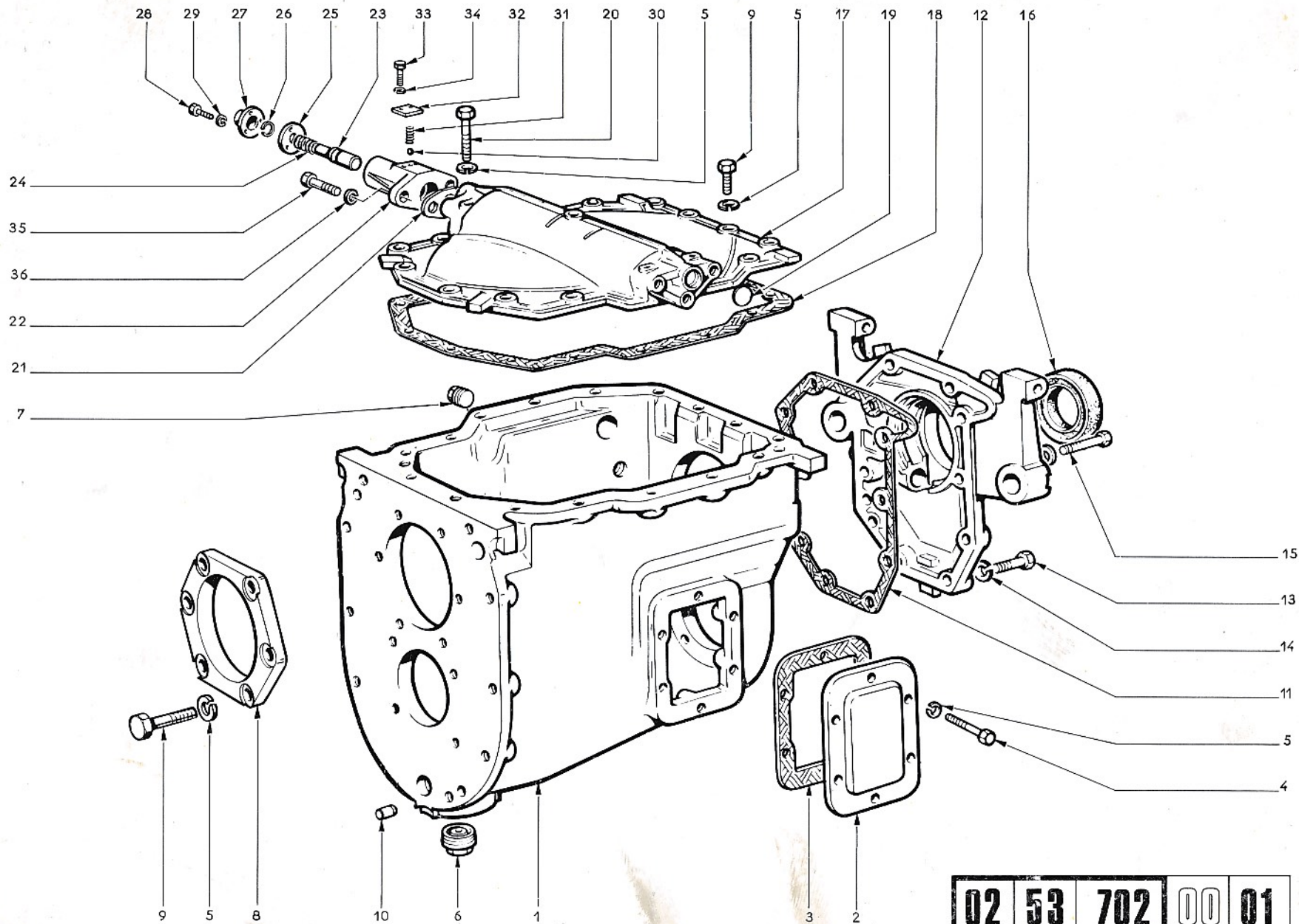

02	53	702	00	01
1	2	3	4	5

6	7	8	9	10
1	4661786	CARTERS BV EMB	1	
2	981630	COUVERCLE PM	1	
3	981633	JOINT	1	
4	15970721	VIS	6	
5	10516870	RONDELLE	28	
6	14326840	BOUCHON	1	
7	14324640	BOUCHON	1	
8	4573277	FLASQUE	1	
9	15970921	VIS	24	
10	4551326	PIED	1	
11	4541954	JOINT	1	
12	4541953	COUVERCLE	1	
13	15540721	VIS	10	
14	10517070	ECROU	14	
15	15540921	VIS	4	
16	40000411	JOINT	1	
17	61578622	COUVERCLE	1	
18	4549872	JOINT	1	
19	10159000	BOUCHON	1	
20	15888821	VIS	4	
21	61578621	JOINT	1	
22	61578768	BOITIER BUTEE	1	
23	61578388	DOIGT	1	
24	61206276	RESSORT	1	
25	61578389	PLAQUE	1	

10	11

6	7	8	9	10
26	61702104	CLIP	1	
27	61578390	PRCTECTEUR	1	
28	61803052	VIS	3	
29	61815222	RONDELLE	3	
30	61702054	BILLE	1	
31	61706096	RESSORT	1	
32	61578391	PLAQUE	1	
33	61803052	VIS	2	
34	61815222	RONDELLE	2	
35	61803107	VIS	2	
36	61815224	RONDELLE	2	

10	11

02 53 702**00 02**

DÉSIGNATION PLANCHE : SE RÉFÉRER AUX PAGES "SOMMAIRE"

PLATE DESIGNATION : REFER TO FLYLEAF

BILDBESCHRIFTUNG : SIEHE VORSATZBLÄTTER



1 2 3 4 5

6	7	8	9	10
1	4651149	CARTERS EMB BV	1	
2	4596898	JCINT	1	
3	10517070	RONDELLE	10	
4	15540621	VIS	10	
5	4007195	SOUFFLET	1	
6	40000521	JCINT	1	
7	4584136	JOINT	1	
8	8559077	SUPPORT BUTEE	1	
9	10516870	RONDELLE	6	
10	15970921	VIS	6	
11	4541805	PLAQUETTE	2	
12	15970921	VIS	4	
13	4007194	RESSORT	2	
14	4603127	PLAQUE	1	
15	4577306	ROTLLE	1	
16	4573272	VIS	1	
17	4573272	COUVERCLE	1	
18	11288021	VIS	4	
19	10516870	RONDELLE	4	
20	4512368	MANCHON BUTEE	1	
21	4007193	BUTEE	1	
22	4534948	LEVIER CDE EMB	1	
23	4584138	CYL INDRE	1	
24	15971621	VIS	2	
25	10516870	RONDELLE	2	

10	11

6	7	8	9	10
26	11306921	VIS	4	
27	10516870	RONDELLE	4	
28	4553120	JCINT	1	
29	4553118	COUVERCLE	1	
30	16043421	VIS	4	
31	10516670	RONDELLE	4	
32	4541313	JOINT	1	
33	4600943	PISTON	1	
34	4553119	JCINT	1	
35	4552479	FOURCHETTE	1	
36	4018702	VIS	1	
37	4552481	JCINT	1	
38	4569943	BOUCHON	1	
39	10296160	JCINT	1	
40	4594433	RESSORT	1	
41	20063480	BILLE	1	

10	11

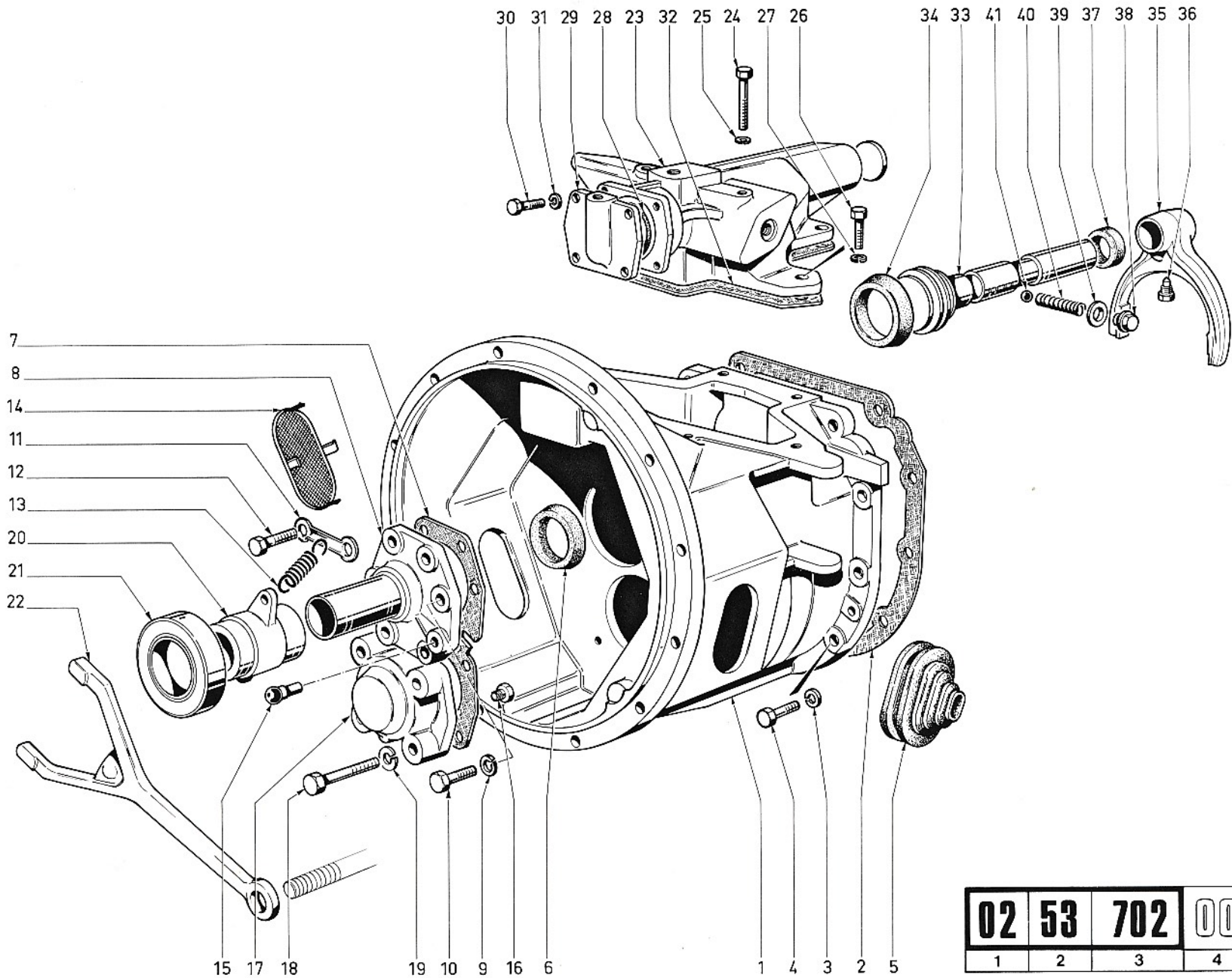

02	53	702	00	02
1	2	3	4	5

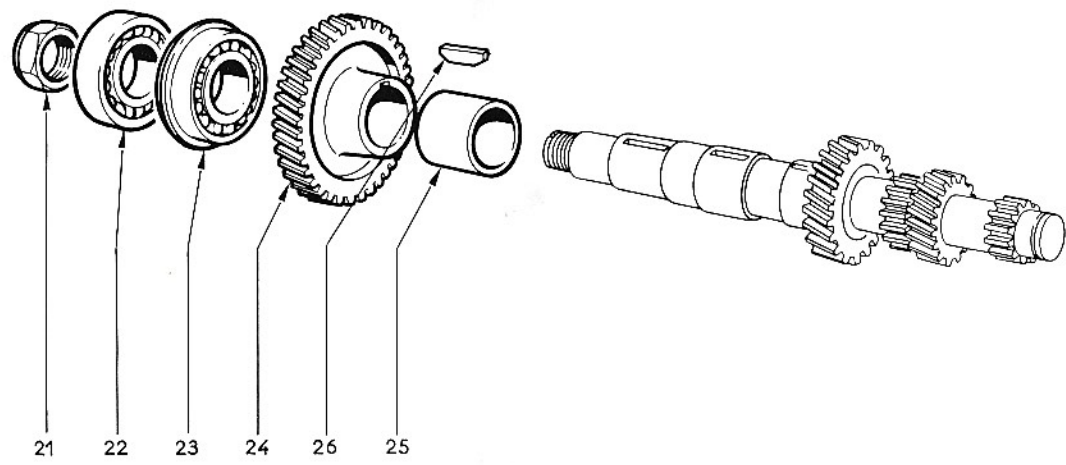
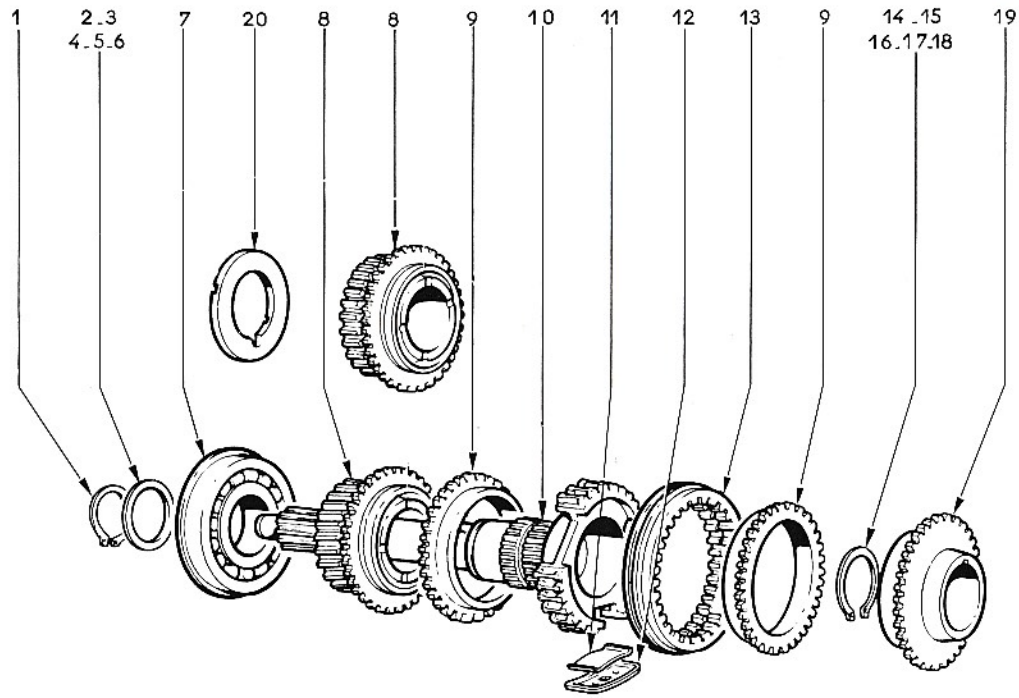

02	53	702	00	03
1	2	3	4	5

6	7	8	9	10
1	4501004	CIRCLIPS	1	
2	4500993	RONDELLE EP 4		68
3	4500994	RONDEL EP 4 5		68
4	4500995	RONDEL EP 4 10		68
5	4500996	RONDEL EP 4 15		68
6	4500997	RONDEL EP 4 20		68
7	4652080	ROULEMENT	1	
8	8559846	PIGNON	1	
9	4541695	SYNCHRO	2	
10	8559844	ARBRE	1	
11	8559848	RESSORT	1	
12	8559849	PORTE RESSORT	1	
13	4592839	MANCHON	1	
14	4500998	CIRCLIP E 2 50		68
15	4500999	CIRCLIP E 2 55		68
16	4501000	CIRCLIP E 2 60		68
17	4541864	CIRCLIP E 2 65		68
18	4541865	CIRCLIP E 2 70		68
19	4541863	PIGNON	1	
20	4578164	RONDELLE	1	
21	4006214	ECROU	1	
22	4573276	ROULEMENT	1	
23	4573275	ROULEMENT	1	
24	4581140	PIGNON	1	
25	4558052	ENTRETOISE	1	

6	7	8	9	10
26	4581139	CLAVETTE	1	

10	11
68	Quantités : au choix <i>Quantities : as desired</i> <i>Mengen : nach Wahl</i>

10	11

02	53	702	00	04
1	2	3	4	5

DÉSIGNATION PLANCHE : SE RÉFÉRER AUX PAGES "SOMMAIRE"

PLATE DESIGNATION : REFER TO FLYLEAF

BILDBESCHRIFTUNG : SIEHE VORSATZBLÄTTER



6	7	8	9	10
1	462918C	PIGNON CDE 1ER	1	
2	4608146	BAGLE	1	
3	4549864	MANCHON 1ERE	1	
4	4629179	PIGNON CDE 2EM	1	
5	4608145	BAGLE	1	
6	4541874	SYNCHRO	1	
7	454986C	MANCHON 2E 3E	1	
8	4006234	CIRCLIPS EP3		68
9	4006235	CIRCLIPS EP305		68
10	4006236	CIRCLIPS EP310		68
11	8559848	RESSORT SYNCHR	2	
12	8559849	PORTE RESSORT	2	
13	4592767	MANCHON	1	
14	4541874	SYNCHRO	1	
15	4628845	PIGNON CDE 3EM	1	
16	4628844	PIGNON CDE 4EM	1	
17	4500992	ANNEAL	1	
18	4541874	SYNCHRO	1	
19	4549857	MANCHON 4E 5E	1	
20	4592767	MANCHON	1	
21	4541874	SYNCHRO	1	
22	4500998	CIRCLIPS E2 50		68
23	4500999	CIRCLIPS E2 55		68
24	4501000	CIRCLIPS E2 60		68
25	4541864	CIRCLIPS E2 65		68

6	7	8	9	10
26	4541865	CIRCLIPS E2 70		68
27	4541853	CIRCLIPS E2 75		68
28	4541854	CIRCLIPS E2 80		68
29	745046	CGUSSINET	1	
30	4628842	PRISE DIRECTE	1	
31	8559008	RCULEMENT	1	
32	4551360	CCUSSINET	1	
33	4628843	ARBRE PRIMAIRE	1	
34	4628847	PIGNON CDE M A	1	
35	4549871	CLAVETTE	2	
36	980092	CLAVETTE	2	
37	4542249	CLAVETTE	1	
38	4554069	FLASQUE	1	
39	4536134	RCULEMENT	1	
40	4006214	ECROU	1	

10	11
68	Quantités : au choix Quantities : as desired Mengen : nach Wahl

10	11

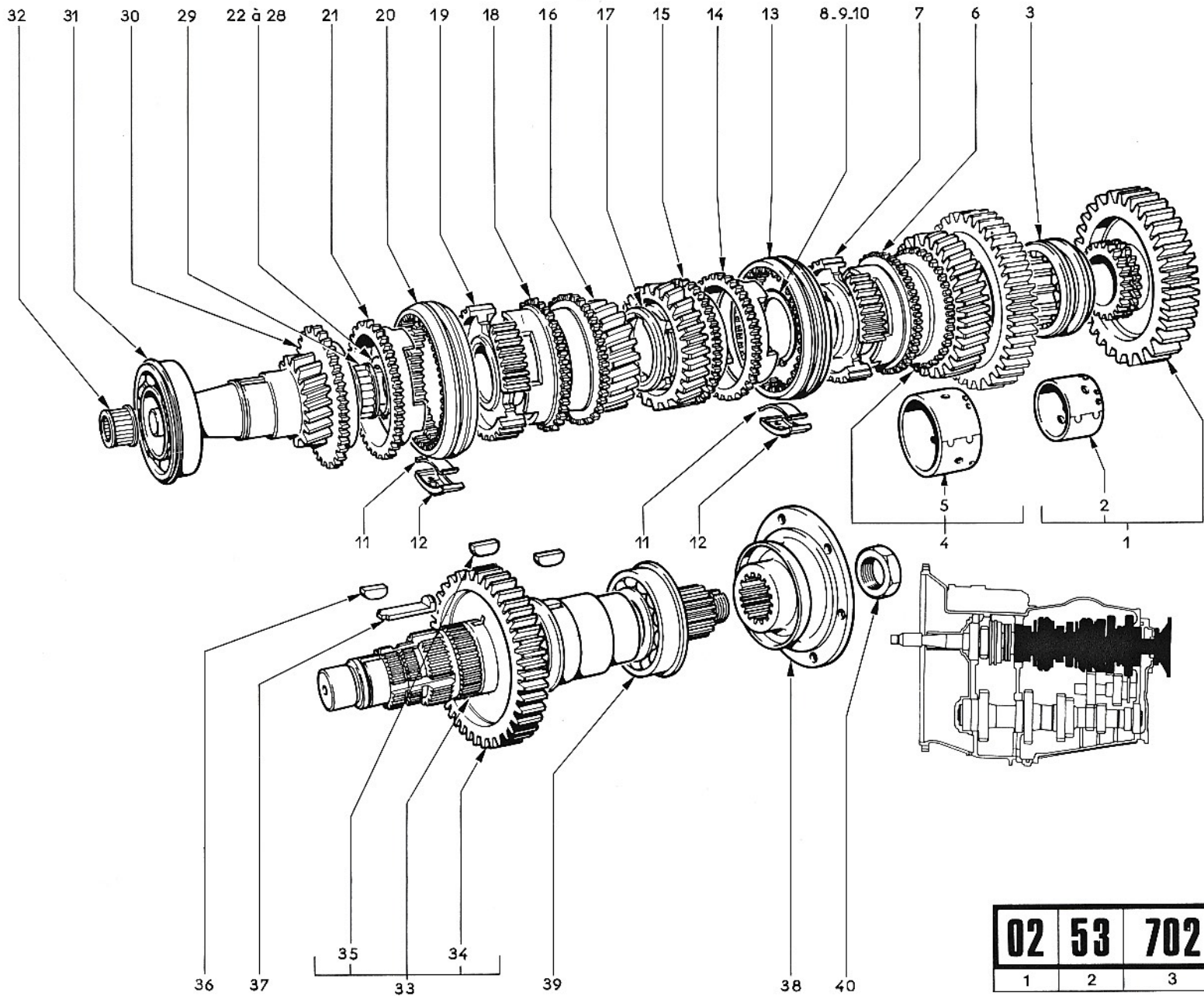

02	53	702	00	04
1	2	3	4	5

02	53	702	00	05
1	2	3	4	5

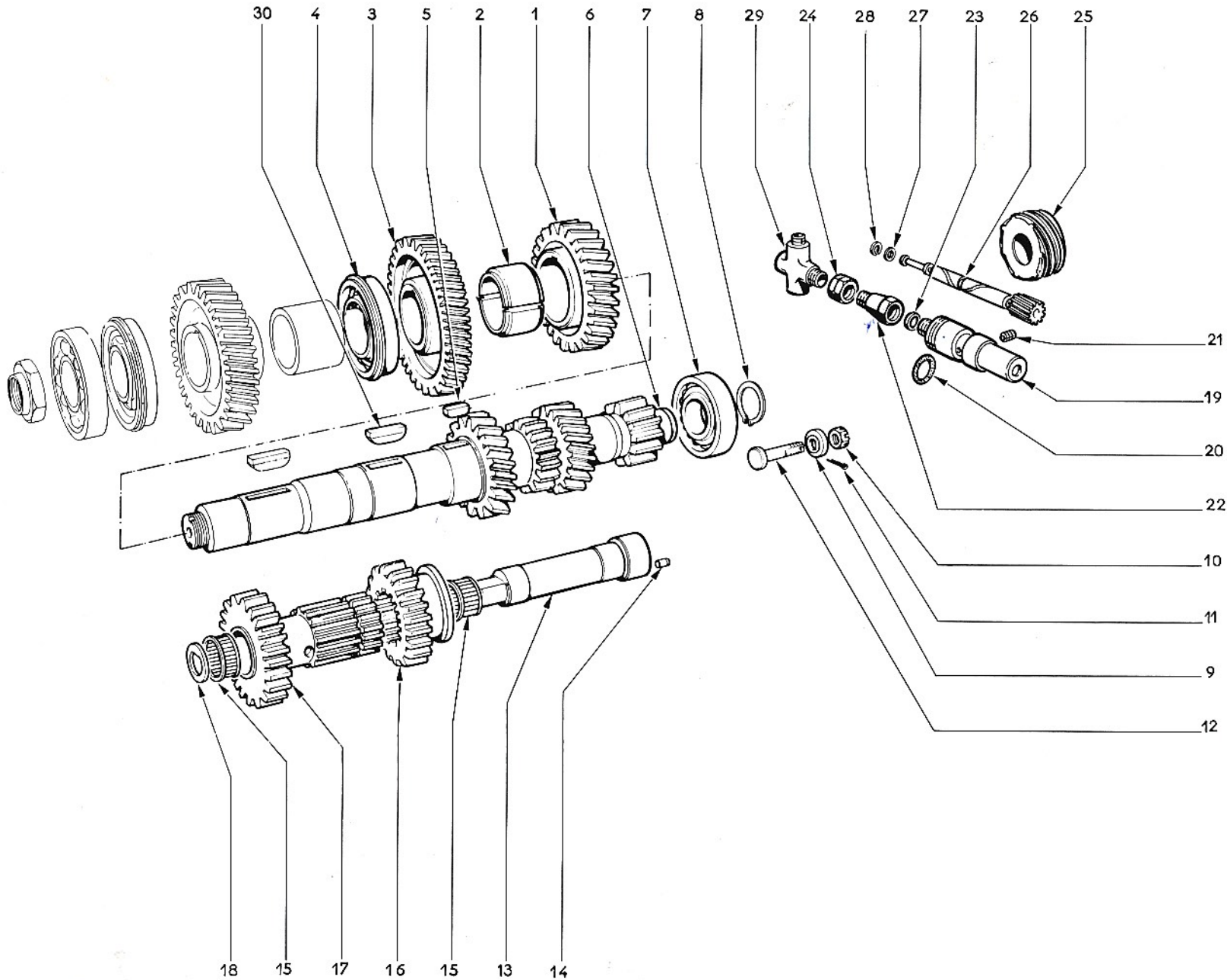

6	7	8	9	10
1	4628852	PIGNON CDE 4EM	1	
2	4573269	ENTRETOISE	1	
3	4628851	PIGNON CDE P D	1	
4	4573271	ROLLEMENT	1	
5	4549871	CLAVETTE	1	
6	4628850	ARBRE SECOND	1	
7	28043930	ROULEMENT	1	
8	4020439	CIRCLIPS	1	
9	4559137	RONDELLE	1	
10	16105611	ECROU	1	
11	10734401	GOLPILLE	1	
12	4559136	AXE	1	
13	4549867	ARBRE MARCH AR	1	
14	10839710	ERGOT	1	
15	4598529	COUSSINET	2	
16	4628854	PIGNON MARC AR	1	
17	4628853	PIGN CDE MAR A	1	
18	4581889	RONDELLE	1	
19	4021175	SUPPORT	1	
20	4555872	JOINT	1	
21	751592	ERGOT	1	
22	61579448	EMBOUT	1	
23	40000671	JOINT	1	
24	716189	ECROU	1	
25	4502536	ROUE CDE 7 FIL	1	

6	7	8	9	10
26	4537948	PIGNON 13 DTS	1	
27	716188	ANNEAU	1	
28	11088075	CIRCLIPS	1	
29	4620708	RACCORD	1	
30	4581139	CLAVETTE	1	

10	11

10	11

02	53	702	00	06
1	2	3	4	5



DÉSIGNATION PLANCHE : SE RÉFÉRER AUX PAGES "SOMMAIRE"

PLATE DESIGNATION : REFER TO FLYLEAF

BILDBESCHRIFTUNG : SIEHE VORSATZBLÄTTER



6	7	8	9	10
1	4606947	CAPUCHON	1	
2	4607716	LEVIER	1	
3	4606932	AXE	1	
4	16043621	VIS	1	
5	10516670	RONDELLE	1	
6	4632428	SUPPORT	1	
7	4551518	ECROU	1	
8	4632427	AXE CDE FOURCH	1	
9	4541981	SOUFFLET	1	
10	4023997	RONDELLE	1	
11	4023998	RONDELLE	1	
12	4023999	RESSORT	1	
13	4638529	RESSORT	1	
14	4534922	JOINT	1	
15	4541985	SECTEUR	1	
16	4549878	LEVIER CDE M A	1	
17	4541986	SECTEUR	1	
18	4018702	VIS	2	
19	4647694	AXE	1	
20	4647695	FOURCHETTE 1E	1	
21	4596897	FOURCHETTE 2 3	1	
22	20063480	BILLE	1	
23	4647697	RESSORT	1	
24	4647696	FOURCHETTE 4 5	1	
25	4541996	AXE	1	

10	11

6	7	8	9	10
26	10300571	BCUCHON	1	
27	10296160	JCINT	1	
28	4647697	RESSORT	1	
29	4541997	SIEGE	1	
30	20063480	BILLE	1	
31	4541998	PLAQUE	1	
32	11066875	CLIP	1	

10	11

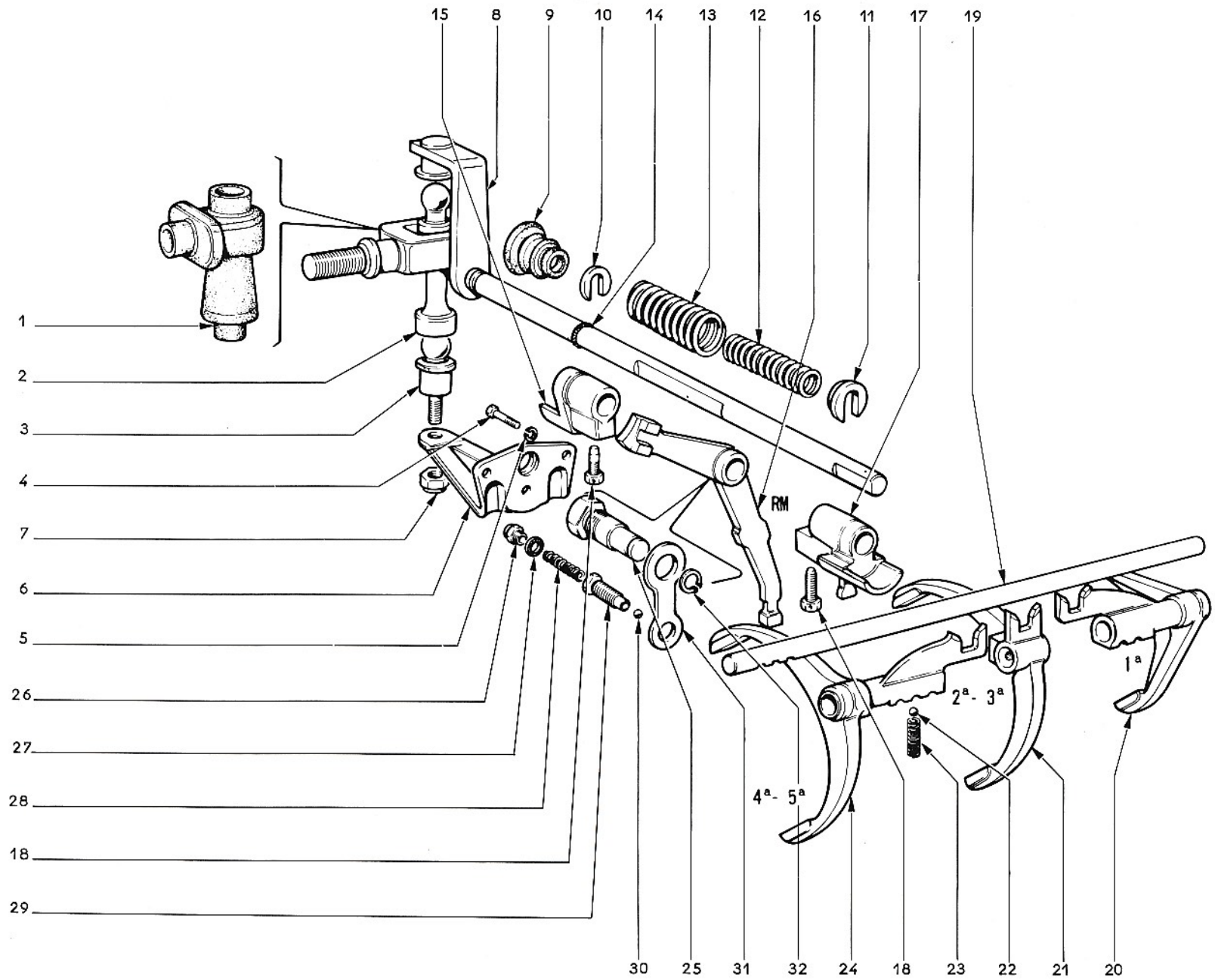

02	53	702	00	06
1	2	3	4	5

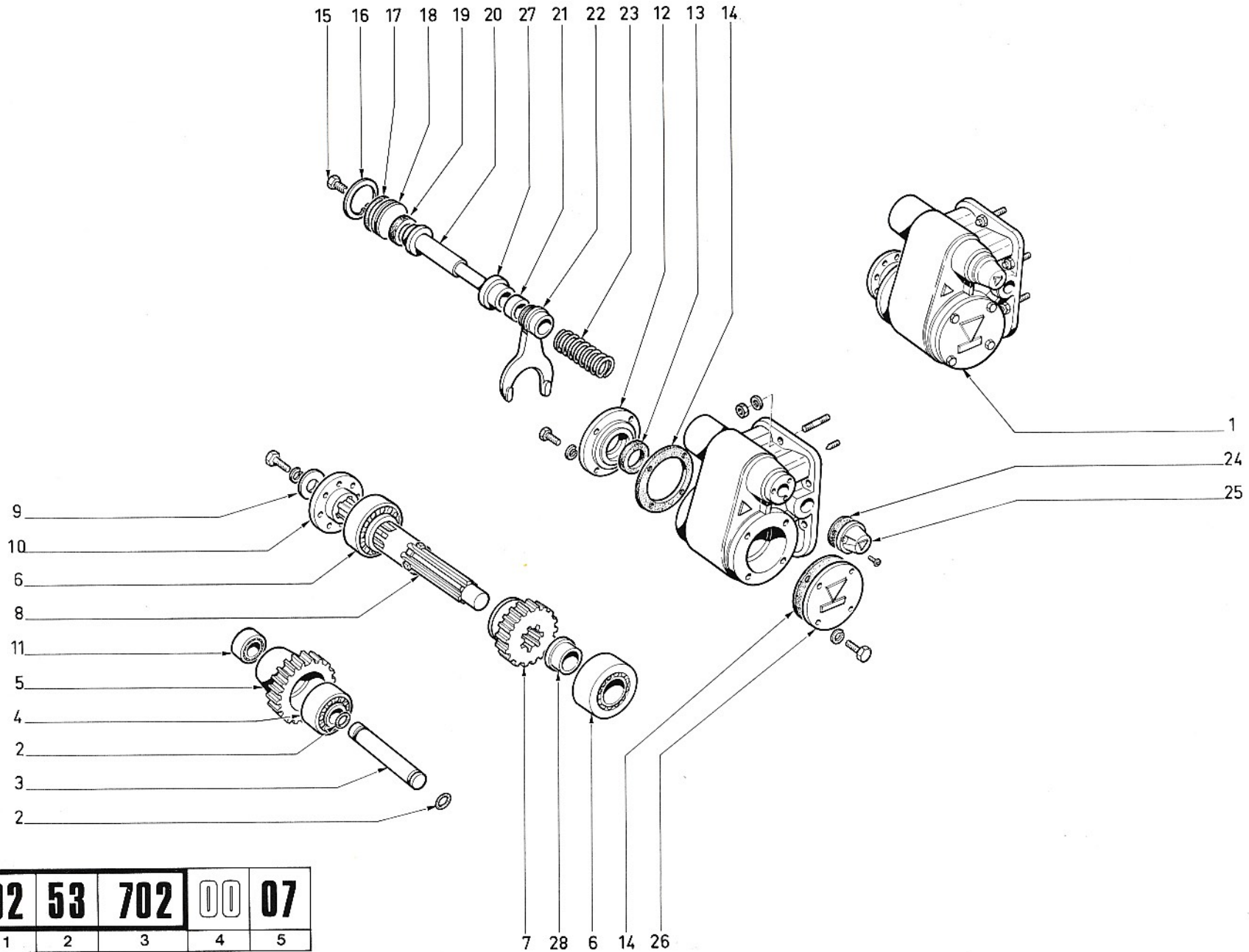

02	53	702	00	07
1	2	3	4	5

7 28 6 14 26

6	7	8	9	10
1	61672573	PRISE MOUVT AS	1	
2	44097236	JOINT	1	
3	44097237	AXE	1	
4	44097238	ROULEMENT	1	
5	44097239	PIGNON	1	
6	26800130	ROULEMENT	1	
7	44097246	PIGNON	1	
8	44097095	ARBRE	1	
9	44097230	RODCELLE	1	
10	44097004	PLATEAU ENTRA	1	
11	44097240	ROULEMENT	1	
12	44097228	COUVERCLE	1	
13	44097074	JOINT	1	
14	44097075	JOINT	2	
15	44097076	RACCORD	1	
16	44097153	ANNEAU	1	
17	9915133	JOINT	1	
18	44097110	COUPELLE	1	
19	44097027	JOINT	1	
20	44097098	PISTON	1	
21	44097241	ENTRETOISE	1	
22	44097049	FOURCHETTE	1	
23	44097064	RESSORT	1	
24	44097255	JOINT	1	
25	44097156	COUVERCLE	1	

10	11

6	7	8	9	10
26	44097197	COUVERCLE	1	
27	44097050	ENTRETOISE	1	
28	44097101	BAGUE	1	

10	11